

**SPECIFICATION SHEET**

**FM/1 STu time switch module**

**PRODUCT/ORDER CODE**

FM/1 STu                                  single channel                                  16 Amps

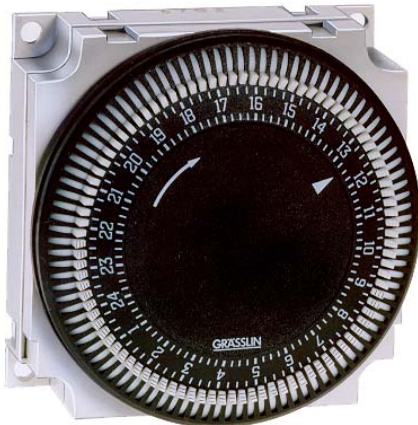

This product is a synchronous motor driven time switch module. The standard unit has a 24 hour dial. A 7-day variant is available on request. Switching is carried out by setting of tappets within the dial. There are 96 "captive" tappets at 15 minute increments. The FM/1 is suitable for "sub-panel" mounting. Four fixing holes on 54mm centres are provided within the base of the housing.

**Technical specification:**

Control panel cutout	62.5mm Ø
Weight	75g
AC switching capacity:	
- resistive load	16A 250v AC
- inductive load cos Ø 0.6	8A 250v AC
- incandescent lamp load	135W
- fluorescent or SON lamp load	100W
Minimum switching current	100mA (20v) AC/DC
Contact type	volt-free changeover
Connection	5 x DIN 6.3mm tab terminals
Ambient temperature	-20 <sup>0</sup> C to +85 <sup>0</sup> C
Accuracy	mains synchronised
Minimum switching time	15 minutes

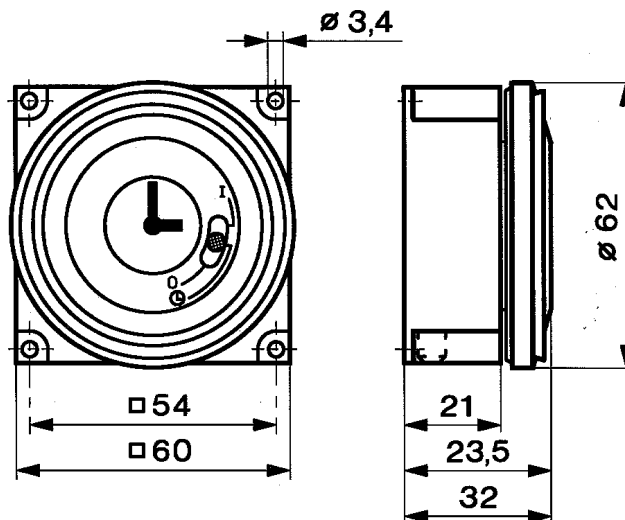

Dimensional details : FM/1 modules